

ALKALINE-MANGANESE DIOXIDE BATTERY

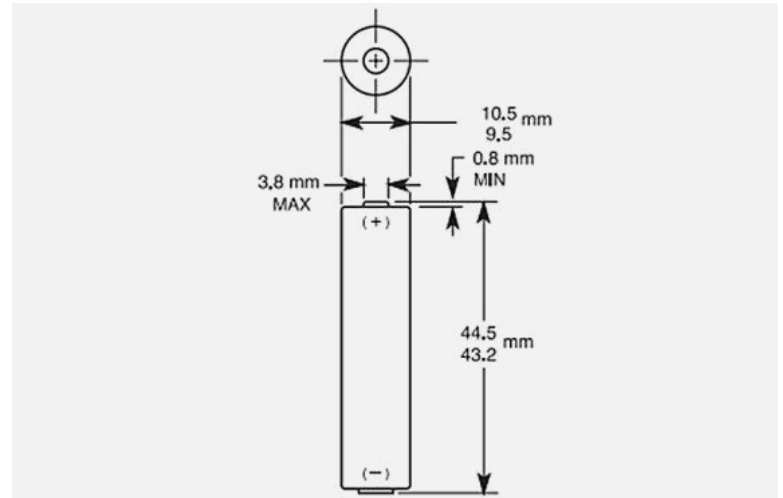

Size: AAA (LR03) PX2400



Dimensions shown are IEC standards

KEY FEATURES

- Reliable Performance
- Excellent resistance to corrosion
- Designed to meet all major quality, safety and environmental standards:
 - Safety: IEC 60086-5
 - ANSI C 18.1M, Part-2
 - EU Battery Directive
 - Quality: ISO 14001 and 9001, Duracell World Class Continuous Improvement Program

TYPICAL APPLICATIONS

- Blood pressure monitors
- Soap dispensers
- Flashlights
- Pulse oximeters

ELECTRICAL CHARACTERISTICS

- | | |
|--|-----------|
| ▪ Nominal capacity (5 mA Cont., .8V cut-off) | 1,461 mAh |
| ▪ Typical Voltage (at + 20 °C) | 1.5 V |
| ▪ AC Impedance @ 1kHz | 129 mΩ |

PHYSICAL CHARACTERISTICS

- | | |
|------------------|--|
| ▪ Typical weight | 11.6 g (0.4 oz) |
| ▪ Typical volume | 3.5 cm ³ (0.2 in ³) |
| ▪ Terminals | Flat |

OPERATING & STORAGE CONDITIONS

- | | |
|--|----------------------------------|
| ▪ Operating temperature range | -20°C to 54°C
(-4°F to 130°F) |
| ▪ Recommended Storage (storage area should be clean, cool, dry and ventilated) | 5°C to 30°C
(41°F to 86° F) |

TYPICAL PERFORMANCE

Constant Current

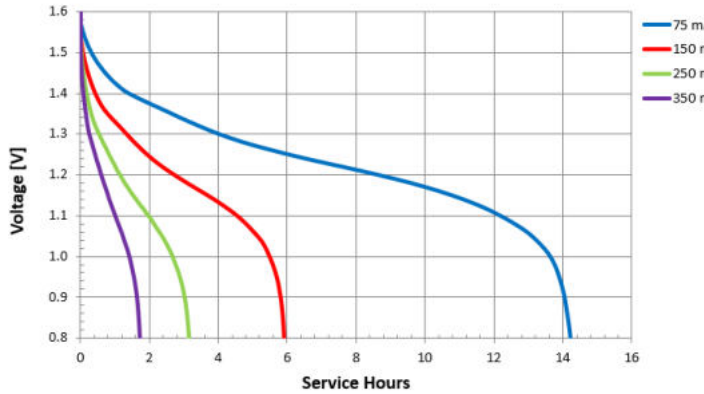

Constant Resistance



Constant Power

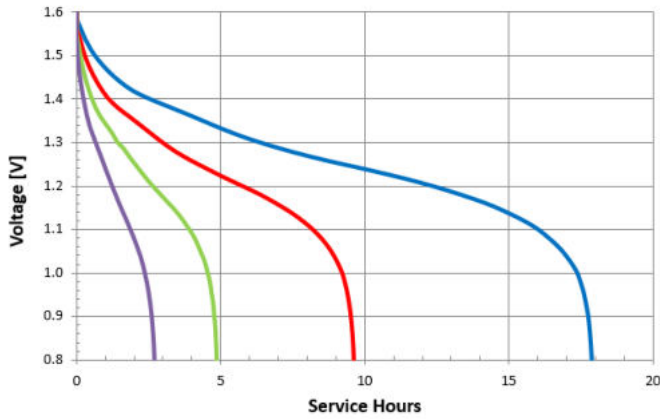

Constant Temperature - 150 mA

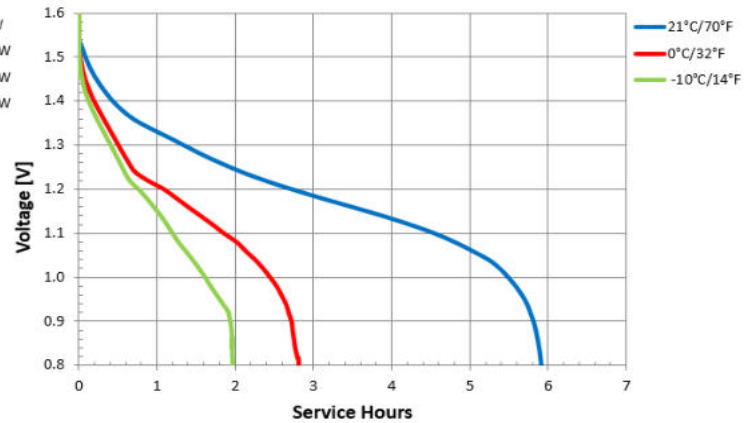

Typical Internal Resistance

High Rate: 0.3A/5 min - 0.6A/1 sec to 0.8V
Low Rate: 0.03A/5 min - 0.15A/1 sec to 0.8V

